

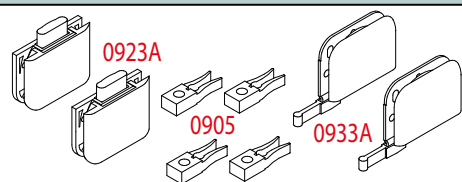

KIT 0923-933A - MAX 15 KG



Legenda KIT / Kit Legend

0905	Fermo superiore ed inferiore <i>Upper and lower stopper</i>
0923A	Catenacciolo superiore con placca per anta in vetro <i>Upper security chain with plate for glass door</i>
0933A	Carrello inferiore con placca per anta in vetro <i>Lower truck with plate for glass door</i>

Legenda altri componenti Legend other items

0920	Profilo alluminio superiore ed inferiore <i>Upper and lower aluminium profile</i>
0930	Profilo alluminio inferiore <i>Lower aluminium profile</i>

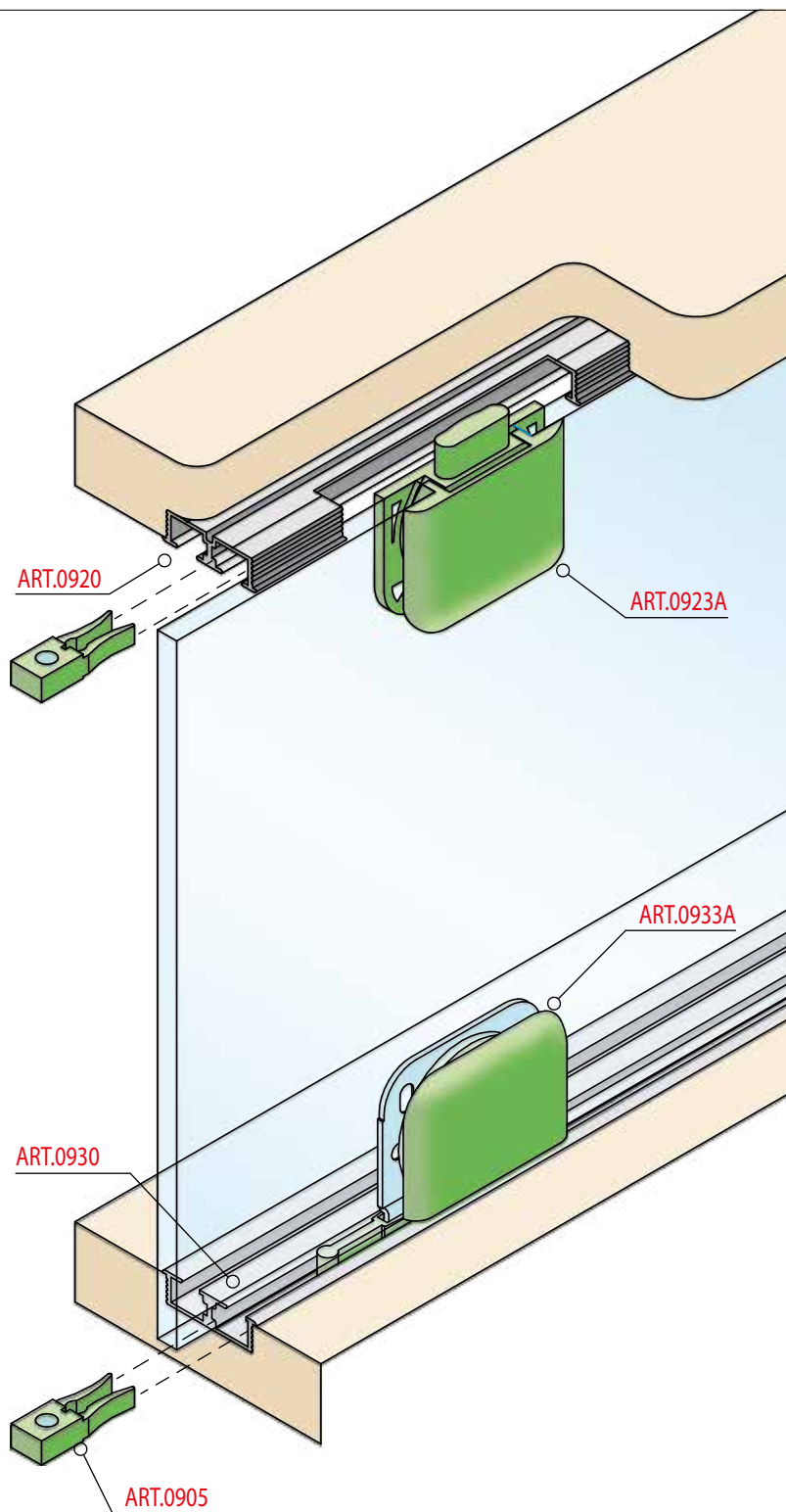



Sezione verticale / Vertical section

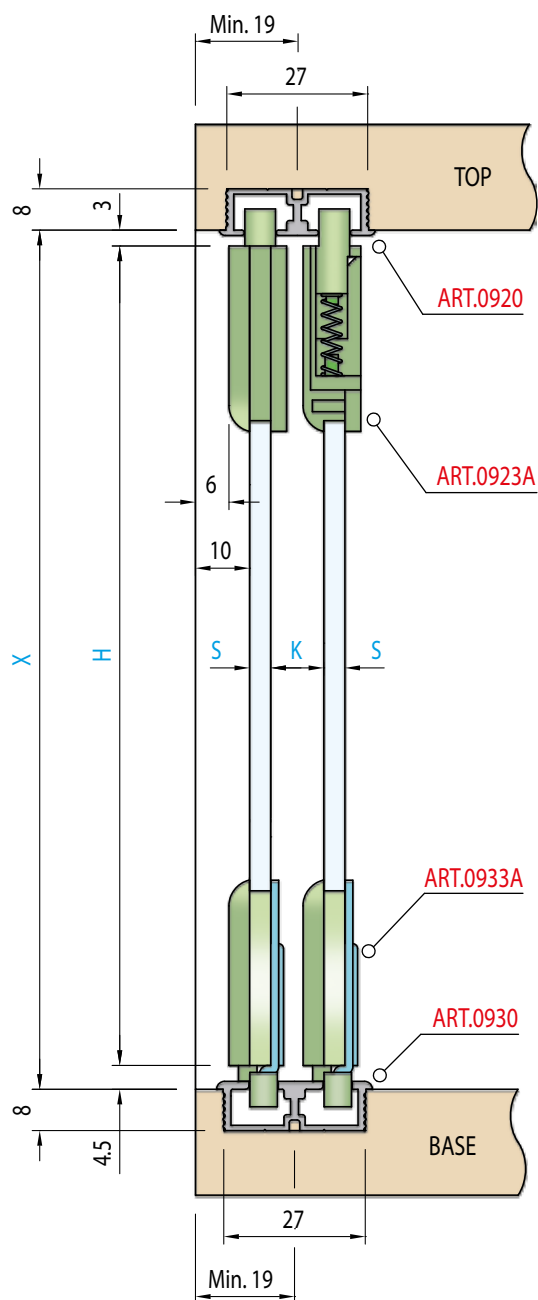

Peso massimo anta Kg. 15
Maximum door weight Kg. 15

S =	da 4 a 6 mm from 4 to 6 mm
K =	da 8 a 10 mm from 8 to 10 mm
H =	X -7,5

S* (spessore / thickness)

Schema Foratura ante / Doors drilling

